

# Clarke®

## POWER



WARNING: Do not use the generator without reading this manual

## 2200W INVERTER GENERATOR

### MODEL NO: IG2300

PART NO: 8877121

## OPERATION & MAINTENANCE INSTRUCTIONS

UK  
CA | CE



ORIGINAL INSTRUCTIONS

DL0724

---

## **INTRODUCTION**

---

Before you use this product, read this manual and follow the instructions carefully. In doing so you will ensure the safety of yourself and others around you, and you can also expect your purchase to give you a long and satisfactory service.

---

## **GUARANTEE**

---

This product is guaranteed against faulty manufacture for a period of 12 months from the date of purchase. Please keep your receipt which will be required as proof of purchase.

This guarantee is invalid if the product is tampered with in any way, or not used for the purpose for which it was intended.

Faulty goods should be returned to their place of purchase, no product can be returned to us without prior permission. This guarantee does not effect your statutory rights.

---

## **ENVIRONMENTAL PROTECTION**

---



Recycle unwanted materials instead of disposing of them as waste. All tools, accessories and packaging should be sorted and taken to a recycling centre for disposed in a manner compatible with the environment.

By purchasing this product, the customer is taking on the obligation to deal with its safe disposal in accordance with the Waste Electrical and Electronic Equipment (WEEE).

In effect, this means that this product must not be disposed of with general household waste. It must be disposed of according to the laws governing Waste Electrical and Electronic Equipment (WEEE) at a recognised disposal facility. If disposing of this product or any damaged components, do not dispose of with general waste. This product contains valuable raw materials. Metal products should be taken to your local civic amenity site for recycling of metal products.

## SPECIFICATIONS

Engine	Engine Model	KM152F
	Type	Petrol
	Displacement (cc)	98
	RPM	5200
	Ignition type	T.C.I
	Fuel tank capacity (L)	5.6
	Fuel Consumption at 3/4 Load (L/h)	1.1
	Maximum run time at 3/4 load (h)	Approx. 6h 15m
	Engine oil capacity (L)	0.35
	Emissions (g/kWh) CO, HC, NOx	245.89, 5.07, 3.89
	Guaranteed sound power (LWA dB)	95
Generator	Rated Frequency (Hz)	50
	Rated AC Voltage per 13A socket x 2 (V)	230
	Rated DC Voltage per socket x 1 (V)	12
	Rated Output Current (A)	8.7
	Maximum Rated Output Current (A)	9.6
	Rated Output Power: (Continuous) (W)	1840
	Maximum Rated Output Power (W)	2200
	Output Type	Sine Wave
	Starter Type	Recoil
	Operating Temperatures	-5°C to 40°C
	IP Rating	IP23M
Dimensions	Depth x Width x Height (mm)	465 x 307 x 500
	Unpacked & Unfueled Weight (kg)	21

---

# GENERAL SAFETY RULES

---



**WARNING: EXHAUST FUMES CAN BE EXTREMELY DANGEROUS IF INHALED**

---

## WORK AREA

1. **ALWAYS** use in a well ventilated area.
2. **ALWAYS** position the exhaust outlet away from people.
3. Read these safety instructions before using the equipment.
4. Keep children away from the generator.

## POSITIONING THE GENERATOR

1. Keep the generator at least 1 m (3 ft.) from buildings or other equipment, or the engine may overheat.
2. Place the generator on a solid, flat surface.
3. Make sure the surrounding area is free from any material that could burn or be damaged by heat.
4. **NEVER** move or tilt the generator whilst it is switched on.

## FIRE PREVENTION

1. **ALWAYS** switch the engine OFF when refuelling.
2. **ALWAYS** refuel in a well ventilated area.
3. **NEVER** overfill the fuel tank, only fill to the level specified.
4. **NEVER** smoke whilst refuelling and avoid smoking or using a naked flame near the generator.
5. **NEVER** start the engine if there is spilled fuel. Any spillage must be wiped clean and the generator allowed to dry before attempting to start the engine.

## PREVENTION OF ELECTRIC SHOCK

1. **NEVER** use the generator in the rain or wet conditions unless it is well protected/ under cover. Under these conditions, adequate ventilation **MUST** be provided.
2. **NEVER** operate the generator with wet hands.
3. **NEVER** use water or any other liquids to clean the generator.









4. Make sure you ground (earth) the generator (See pages 9-10).

## **ADDITIONAL SAFETY RULES FOR GENERATORS**

1. **ALWAYS** make sure the applied load does not exceed the generator rating. Overloading the generator is dangerous and could cause serious damage.
2. **ALWAYS** turn off and disconnect any appliance from the generator when carrying out any maintenance.
3. **ALWAYS** allow the generator to reach operating speed before connecting a load.
4. **NEVER** allow the generator to run out of fuel when a load is connected.
5. **NEVER** transport the generator with fuel in the tank.
6. **NEVER** connect the generator to a commercial or residential power supply; e.g. ring main.
7. **NEVER** allow the generator air vents to become blocked.
8. **NEVER** directly cover the generator while in use.

# SAFETY SYMBOLS

The following safety symbols are shown on the product or it's packaging. Please read all of the safety and operating instructions carefully before using this product.

	<p><b>Read instruction manual before use.</b></p>		<p><b>Hot surface - DO NOT TOUCH</b></p>
	<p><b>Dangerous Voltage - Risk of Electrocution.</b></p>		<p><b>Poisonous fumes - DO NOT use the generator in an enclosed space.</b></p>
	<p><b>Flammable</b></p>		<p><b>Caution - The user should be aware of a general hazard.</b></p>
	<p><b>DO NOT directly cover the generator while in use</b></p>		<p><b>Earth Connection Point</b></p>

# OVERVIEW - CONTROLS & OUTLETS



NO	DESCRIPTION	NO	DESCRIPTION
1	OFF/ON/CHOKE Fuel Switch	5	DC Protector ON/OFF Switch
2	Economy Control Switch	6	2 Pin 12V/8.3A DC Outlet
3	Reset Button	7	2 x 3 Pin 13A 230V AC Outlets
4	Oil Alarm, Overload & Output Indicator Lights	8	Earth Connection Point

## OVERVIEW - GENERAL COMPONENTS



NO	DESCRIPTION	NO	DESCRIPTION
1	Recoil Starter	4	Spark Plug Cover
2	Fuel Cap/Fuel Tank Vacuum Relief Valve	5	Oil Filler Cap Cover
3	Fuel Gauge		

## UNPACKING AND ASSEMBLY

Unpack your generator and check the following items are present. Should there be any missing or damaged during transit contact your CLARKE dealer.

1 x 2200 Watt Inverter Generator	1 x 12 Volt Crocodile Clip Lead Assembly
1 x Spark Plug Box Spanner with Lever	1 x Oil Funnel



---

# BEFORE USING THE GENERATOR

---

**IMPORTANT: Generators should ALWAYS be earthed. Make sure you earth the generator.**

Before using your generator check that the generator is:

- In good condition and free from any damage.
- Clean and free from fuel or oil spillage.
- Correctly located for use (see page 3).
- Correctly earthed.
- Free from leakage.

**NOTE:** To avoid accidental spillage of fuel, use a funnel to fill the fuel tank. If fuel is spilled it must be removed from the unit before attempting to start the engine.

## EARTHING



**WARNING: IT IS ADVISABLE TO PROPERLY EARTH YOUR GENERATOR BEFORE STARTING, USING A WIRE AND A SMALL METAL EARTH SPIKE. THE WIRE AND EARTH SPIKE ARE NOT SUPPLIED WITH THIS UNIT.**

An earth rod and cable can be purchased at your local camping or electrical supplier, or alternatively an earth rod can be made, and it is suggested you get advice from a qualified electrician.

The cable used should be insulated and a maximum length of 1 metre and a minimum of 1.0mm<sup>2</sup> to carry a 10amp load.

Attach the cable to the generator at the earthing point (shown on the right).

Connect the other end of the cable to a steel or copper earth rod. If you have purchased a rod, make sure you connect it in accordance with the installation instructions supplied with the rod.

When pushing the rod into the ground the generator must not be running and it is suggested that the rod is pushed into the ground by at least 100 mm.

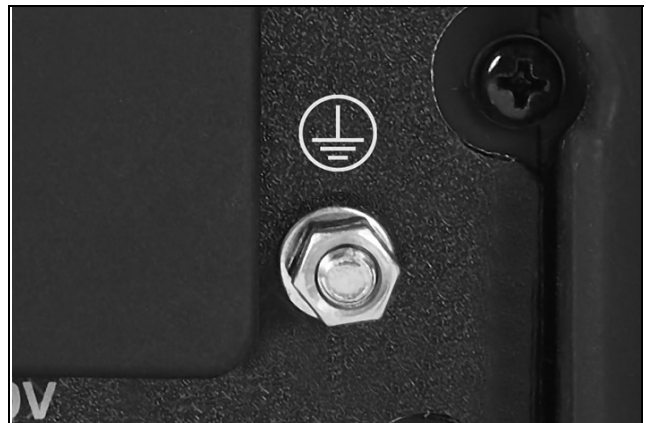

Earthing of generators is covered in BS7430:2011. If you have any doubts about this subject consult a qualified electrician.

## CHECKING & ADDING ENGINE OIL

1. Place the generator on a level surface and check the oil level as follows.

**NOTE:** The oil reservoir capacity is 350ml

2. Remove the oil cap cover located on the side of the generator.

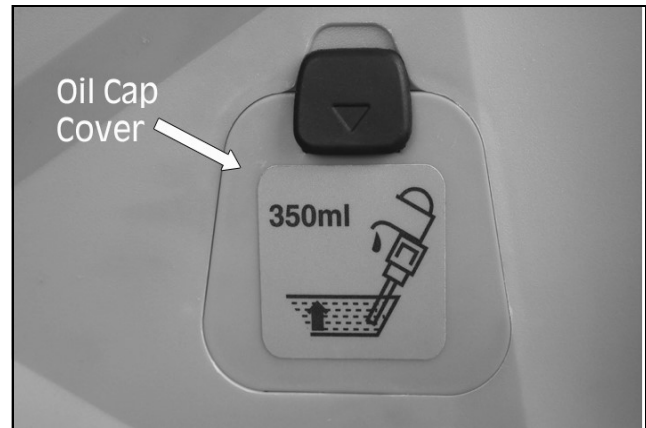

3. Turn the oil filler cap anti-clockwise and remove from the oil reservoir, wipe the dipstick with a clean cloth.
4. Insert the dipstick back into the oil filler tube and then remove it again.

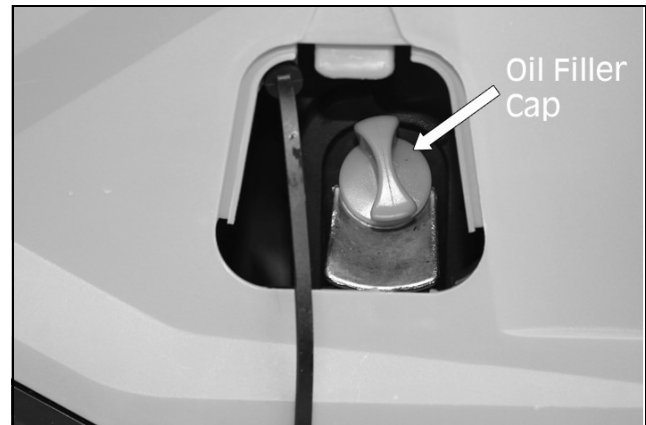

5. If the oil is below the Min. level on the dipstick, top up the oil reservoir with fresh oil using the oil funnel.

- **DO NOT** fill above the max level mark.
- We recommend the use of SAE10W-30 oil in this generator. (CLARKE part number 3050845)

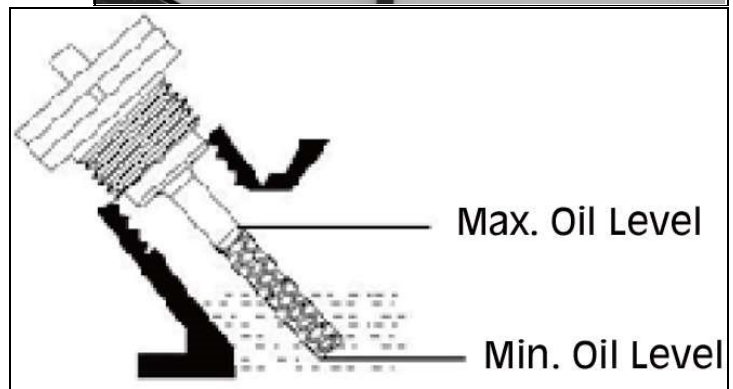

- **DO NOT** tilt the generator when adding engine oil. This could result in overfilling and damage to the engine.

6. Replace the oil filler cap.
7. Replace the oil cap cover.

## CHECKING & ADDING FUEL



**WARNING: MAKE SURE THERE IS FUEL IN THE TANK WHEN USING THE GENERATOR. RUNNING OUT OF FUEL OR STOPPING THE ENGINE SUDDENLY WITH A LOAD CONNECTED COULD CAUSE SERIOUS DAMAGE.**

**WARNING: FUEL IS HIGHLY FLAMMABLE AND POISONOUS.**

**WARNING: SEE GENERAL SAFETY RULES ON PAGE 4 AND READ THEM CAREFULLY BEFORE REFUELING.**

**WARNING: DO NOT FILL ABOVE THE TOP OF THE FUEL FILTER OR IT MAY OVERFLOW WHEN THE FUEL HEATS UP AND EXPANDS.**

**WARNING: WIPE UP ANY SPILLED FUEL IMMEDIATELY.**

**WARNING: AFTER REFUELING, MAKE SURE THE FUEL FILLER CAP IS TIGHTENED SECURELY.**

### RECOMMENDED FUEL

Your generator has been designed to use regular unleaded petrol with an octane number of 86 or higher.

1. Check the fuel level via the fuel gauge window located on top of the generator. A red bar will show the fuel quantity in the tank.

**NOTE:** The fuel tank capacity is 5.6 Litres (Safe Fuel Level).

2. Open the fuel filler cap located on top of the generator.
3. Slowly add fuel to the fuel tank.
  - **DO NOT** overfill the fuel tank.
4. Replace the fuel filler cap securely.
5. Clear up any spillages.

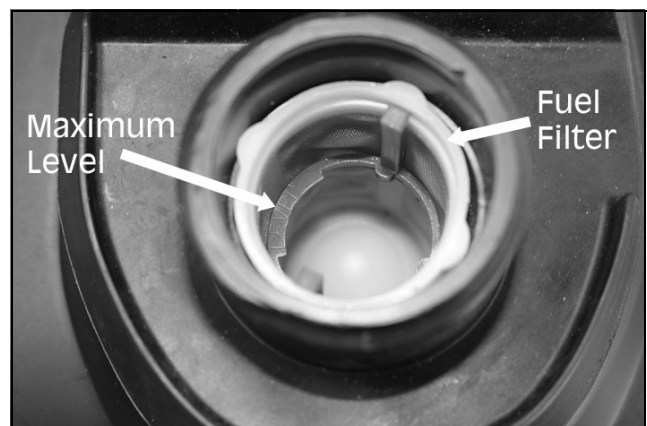
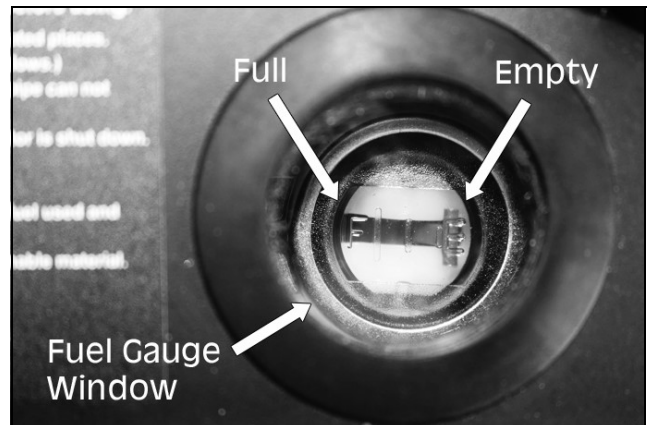

# USING YOUR GENERATOR

## STARTING THE ENGINE

1. Remove all connections from the AC & DC sockets.
2. Check that the generator is correctly earthed, see pages 9 - 10
3. Hold the fuel tank cap so that it will not move and turn the fuel tank vacuum relief valve knob to the 'ON' position.
4. Set the Economy Control Switch to the 'O' - HIGH SPEED MODE' position.
5. Move the OFF/ON/CHOKE Fuel Switch clockwise to the 'CHOKE' position.

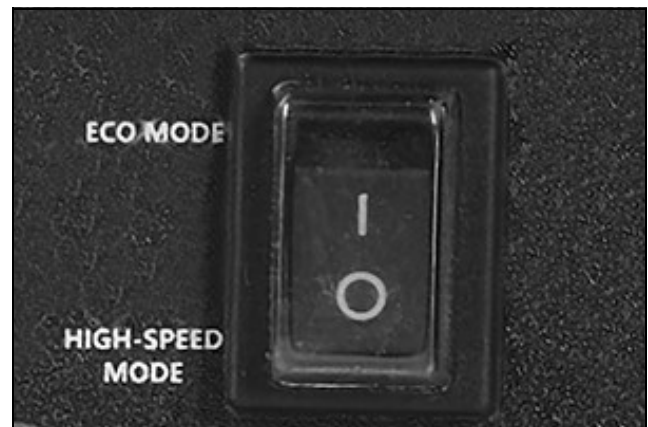
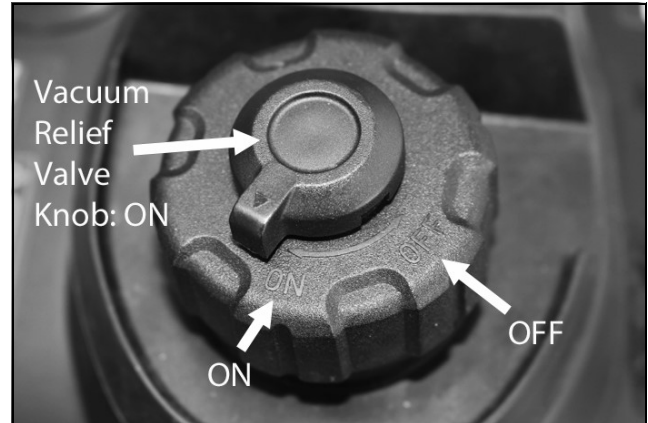

6. Hold the recoil starter handle firmly and pull lightly until you start to feel resistance and then pull up sharply to start the engine.

**NOTE:** You may have to do this more than once.

**NOTE: NEVER** let the handle snap back.

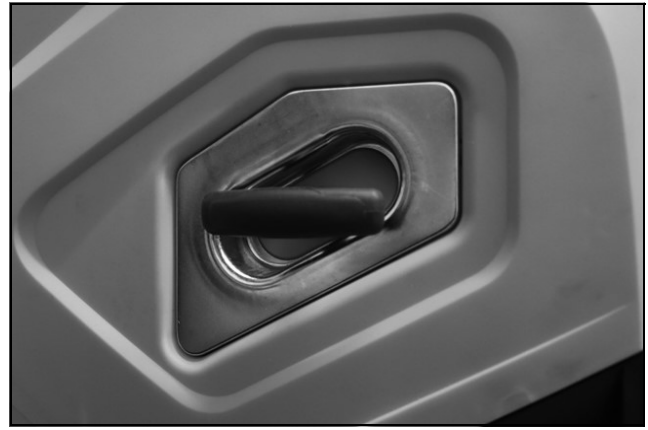

7. Once the engine has started, slowly turn the fuel switch to the 'ON' position.

**NOTE:** Allow the generator to run for several minutes before attempting to connect any electrical devices. This allows the generator to stabilize its speed and temperature.

**NOTE:** When you first start the generator, the overload indicator (see item 4, page 7) may light up for a few seconds, this is normal. If the overload indicator is still lit after 5 seconds, stop the engine and contact your CLARKE dealer or the CLARKE Service Department.



## ECONOMY CONTROL SWITCH

### 'I' (ECO MODE):

Recommended to minimize fuel consumption and further reduce noise levels when no load is applied to the generator. Engine speed varies with the load.

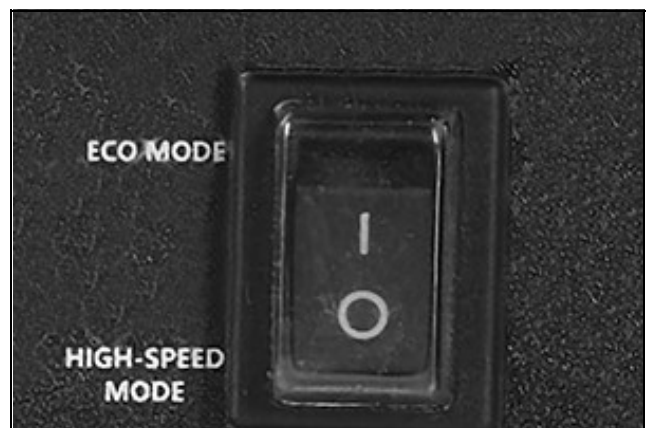

## 'O' (HIGH-SPEED MODE):

The engine will run at the rated speed regardless of whether a load is connected or not. The switch should be in the 'O' position if you are using electrical devices that require a large starting current such as compressors or water pumps.



**CAUTION: THE ECONOMY CONTROL DOES NOT WORK EFFECTIVELY IF THE ELECTRICAL APPLIANCE REQUIRES 'BURSTS' OF POWER.**

**CAUTION: TURN THE ECONOMY CONTROL FEATURE OFF WHEN CONNECTING HIGH LOAD APPLIANCES OR WHEN CONNECTING TO THE DC OUTPUT.**

## CONNECTING ELECTRICAL DEVICES

The generator can supply both 230V AC and 12V DC.

### AC POWER

1. Start the engine. See pages 12-13.
2. Make sure the appliance is turned off before connecting it to the generator.
3. Connect the appliance to the generator using one of the two 3 Pin 13A 230V AC outlets.

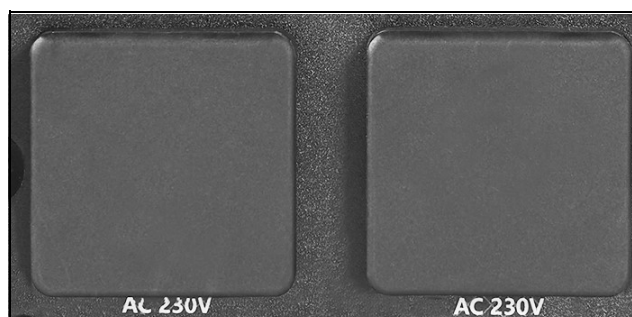

**CAUTION: MAKE SURE THAT THE APPLIANCE BEING CONNECTED IS IN GOOD WORKING ORDER, IF IT BEGINS TO ACT ABNORMALLY OR STOPS SUDDENLY, DISCONNECT IT FROM THE GENERATOR**

**CAUTION: MAKE SURE THE APPLIANCE DOES NOT EXCEED THE MAXIMUM RATED LOAD FOR THE GENERATOR.**

**CAUTION: ANY DEVICE WHICH CONTAINS AN INDUCTIVE LOAD E.G. DEVICES THAT CONTAIN A MOTOR MAY REQUIRE MORE CURRENT ON STARTUP.**

### DC POWER

1. Set the economy control switch to 'O'.
2. Start the generator. See pages 12-13.
3. Make sure the appliance is turned off before connecting it to the generator.
4. Lift the cover and connect the 12V appliance (max 8.3A) to the generator.



## DC POWER (TOPPING UP CAR BATTERIES)



**WARNING: FOR YOUR SAFETY PERFORM THE FOLLOWING INSTRUCTIONS IN THE ORDER SHOWN.**

**WARNING: YOU SHOULD ONLY USE THIS GENERATOR TO 'TOP UP' THE BATTERY AS TRYING TO CHARGE A COMPLETELY FLAT BATTERY MAY CAUSE THE FUSE TO BLOW.**

1. Set the Economy Control Switch to the 'O' - HIGH SPEED MODE' position.
2. Start the generator. See pages 12 - 13.
3. Connect the battery charging leads to the battery.
  - Make sure you clamp the red wire to the positive (+) terminal and the black wire to the negative (-) terminal of the battery.

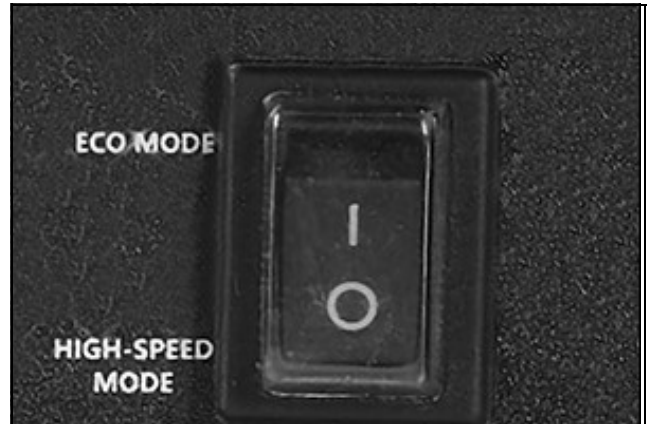

4. Connect the battery charging lead to the generators DC Power socket.
  - The battery will begin to charge
5. Monitor the voltage across the battery regularly during charging and disconnect the battery when the voltage reaches 14.4 volts.



**CAUTION: WHEN DISCONNECTING THE BATTERY, ALWAYS DISCONNECT THE NEGATIVE LEAD FIRST.**

**CAUTION: DO NOT ALLOW THE RED AND BLACK CLAMPS TO TOUCH WHILE STILL CONNECTED TO THE GENERATOR.**

## DC PROTECTOR

The DC protector turns 'OFF' automatically when the electrical device connected to the generator is operating and the current is above the rated flow.

To use this device again, turn the DC protector to the 'ON' position.

**NOTE:** Reduce the load of the connected device below the specified rated output of the generator if the DC protector

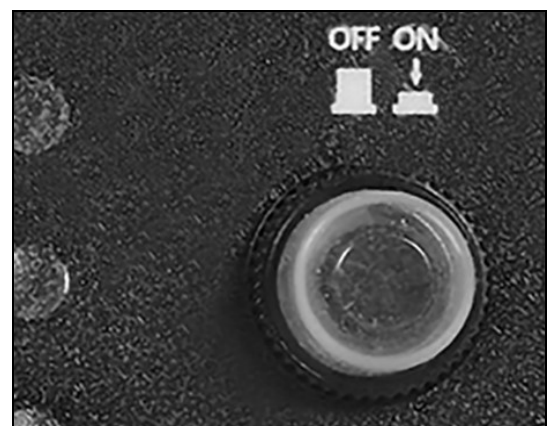

turns 'OFF'. If the DC protector turns off again, stop using the device immediately.

## OVERLOAD RESET

If the overload protector activates, wait for a few minutes and then press the reset switch shown on the right.



## INDICATOR LIGHTS

### OUTPUT

The output indicator (Green) will remain on during normal operation.

### OVERLOAD

The overload indicator (Red) will light up if there is an overload or a short circuit in the connected appliance.

If this happens, proceed as follows:

1. Turn off any connected electrical devices and stop the generator.
2. Reduce the total wattage of connected electric devices to within the rated output of the generator.
3. Check air inlet and around the control unit. If any blockages are found, remove them.
4. After checking, restart the generator.

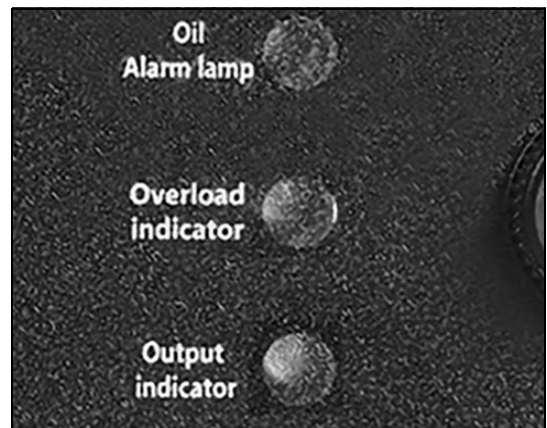

### OIL ALERT

The oil alert indicator (Red) will light up when the oil level is low.

- To add oil, follow the instructions on page 10 - 11.



## SHUTTING DOWN THE GENERATOR

To stop the generator simply turn the OFF/ON/CHOKE Fuel Switch anti-clockwise to the 'OFF' position, as shown.

**NOTE:** Turn off any electric devices.

**NOTE:** Set the economy control switch to the 'O' - HIGH SPEED MODE' position.

1. Disconnect any electric devices.
2. Turn the OFF/ON/CHOKE Fuel Switch to the 'OFF', as shown.



3. Hold the fuel tank cap so that it will not move and turn the fuel tank vacuum relief valve knob to the 'OFF' position.

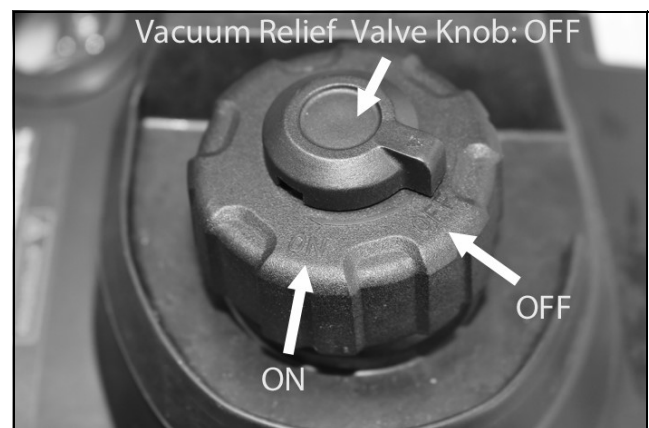

**CAUTION: ALLOW THE GENERATOR TO COOL FOR SEVERAL MINUTES BEFORE TOUCHING AREAS THAT BECOME HOT USING USE.**

**NOTE:** Be sure the engine switch and the fuel tank vacuum relief valve are in the 'OFF' positions when stopping, transporting and storing the generator.

# MAINTENANCE

## CHANGING ENGINE OIL (EVERY 20 HOURS OF USE)



**CAUTION: PROLONGED EXPOSURE TO USED ENGINE OIL IS DANGEROUS, ALWAYS WASH YOUR HANDS THOROUGHLY AFTER HANDLING USED ENGINE OIL.**

1. Unscrew the 3 fixing screws on each corner and remove the maintenance panel shown on the right.



2. Turn the oil filler cap anti-clockwise and remove from the oil tank.
3. Tilt the generator to allow the oil to drain out of the oil reservoir into a suitable container via the drain channel until empty.

**NOTE:** You may need assistance with this step as the generator is heavy.

4. Fill the oil reservoir with fresh oil.
  - **DO NOT** fill above the max level mark (0.35 litres)
  - We recommend the use of SAE10W-30 oil in this generator. (CLARKE part number 3050845)

5. Replace the oil filler cap and maintenance panel.

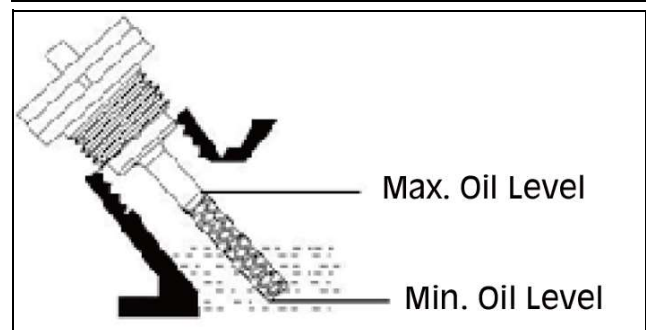

## ENVIRONMENTAL PROTECTION

One of the most damaging sources of pollution is oil. **DO NOT** throw away used engine oil in with your domestic waste or down drains and sinks. Place it in a leak proof container and dispose of it according to local regulations.

## CHANGING AIR FILTER (EVERY 50 HOURS OF USE)



**WARNING: DO NOT USE FLAMMABLE SOLVENTS OR PETROL TO CLEAN THE AIR FILTER.**

1. Unscrew the 3 fixing screws on each corner and remove the maintenance panel shown on the right.



2. Remove the air filter cover screw, shown on the right.
3. Remove the air filter cover.

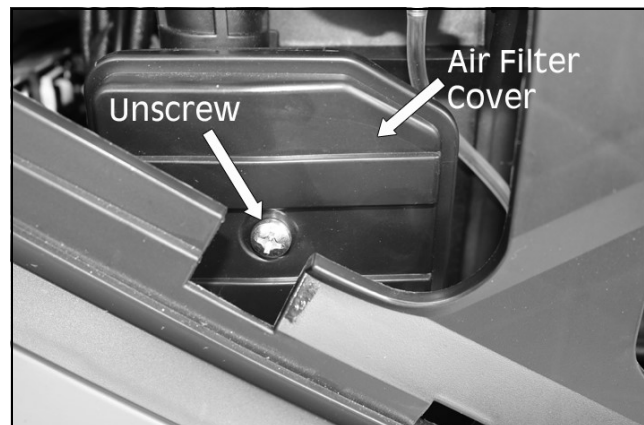

4. Remove the air filter element.
5. If the air filter is damaged contact the CLARKE spare parts department for a replacement.
  - If the filter is dirty, wash it in a solution of warm water and mild detergent and then rinse thoroughly.



- Leave the filter to dry completely. Once it is dry immerse the filter in clean engine oil and squeeze the filter to remove excess oil.
6. Replace the filter into its original position and replace and secure the air filter cover.

## CHANGING SPARK PLUG (EVERY 50 HOURS OF USE)



**CAUTION: ALLOW THE ENGINE TO COOL BEFORE REMOVING THE SPARK PLUG.**

1. Remove the spark plug cover panel located on top of the generator.



2. Remove the spark plug cap from the spark plug.



3. Fit the spark plug box spanner over the spark plug as shown.



4. When the spark plug has been removed, check for discoloration and use a wire brush to remove any carbon build up.

5. Check the spark plug gap (a) with a feeler gauge, it should be between 0.6 and 0.7 mm.

- Adjust if necessary.

6. Check the overall condition of the spark plug and replace if damaged.

**NOTE:** Spark plugs are available from CLARKE Spare Parts department 020 8988 7400.

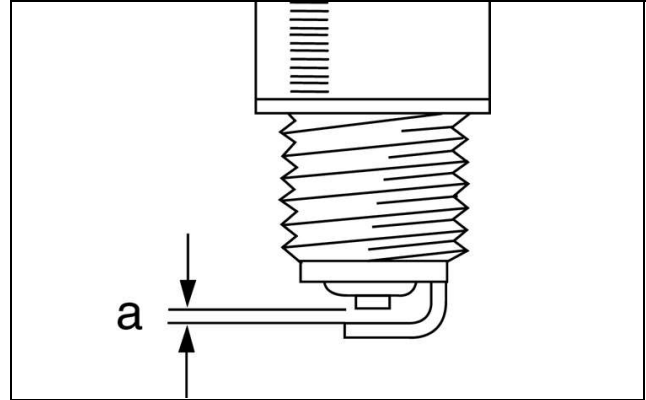

7. Reinstall the spark plug and replace the spark plug cap and top cover.

## **CLEAN FUEL TANK FILTER (EVERY 100 HOURS OF USE OR EVERY 6 MONTHS)**



**CAUTION: ALLOWING PETROL TO SIT IN THE FUEL TANK FOR LONG PERIODS OF TIME CAN MAKE IT DIFFICULT TO START THE GENERATOR IN THE FUTURE. NEVER STORE THE GENERATOR FOR EXTENDED PERIODS OF TIME WITH FUEL IN THE TANK.**

Just inside the fuel tank is a fuel filter. Check this filter periodically and remove any contaminants which may have accumulated.

1. Remove the fuel tank cap.
2. Lift out the filter inside.

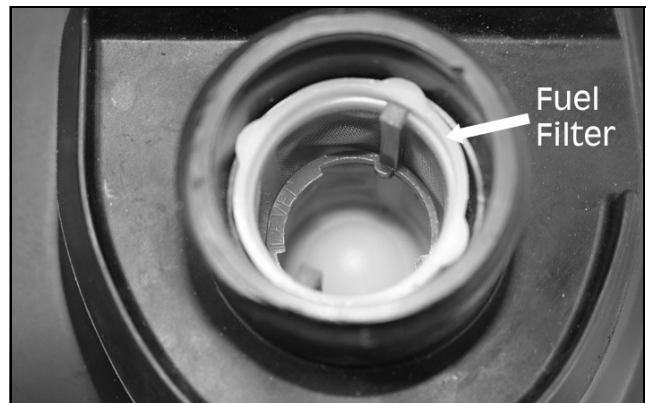

3. Clean the filter with solvent. If the filter is damaged, contact CLARKE Spare Parts department 020 8988 7400 for a replacement.
4. Replace the filter and fuel tank cap.



# TROUBLESHOOTING

<b>PROBLEM</b>	<b>CAUSE</b>	<b>SOLUTION</b>
Engine does not start	OFF/ON/CHOKE Fuel Switch in OFF position	Set OFF/ON/CHOKE Fuel Switch to CHOKE position
	Fuel tank is filled with contaminated or old fuel	Change the fuel in the tank
	Not enough oil in crankcase	Add or replace oil
	Air filter is dirty	Clean or replace air filter
	Spark plug is dirty	Clean spark plug
	Spark plug is broken	Replace spark plug
	Generator is not on level surface	Move generator to a level surface to prevent low oil shutdown from triggering
	Engine needs maintenance	Contact the CLARKE service department for more information
Engine Stops	Generator was tilted when adding oil or shipped side down	Remove spark plug, turn engine switch to the OFF position then pull recoil starter four (4) times to remove oil from the combustion chamber. Replace spark plug and restart engine
	Fuel tank vacuum relief valve on OFF position	Turn fuel tank vacuum relief valve to the ON position
	Not enough oil in crankcase	Add or change oil
Blue smoke in exhaust	Engine is out of fuel	Check fuel gauge and add fuel if needed
	Generator inclined, oil has entered combustion chamber	Move generator to a level position
	To much oil has been added to the crankcase	Drain excess oil

<b>PROBLEM</b>	<b>CAUSE</b>	<b>SOLUTION</b>
Generator runs but does not support all electrical devices connected	Bad connecting wires/cables	If using an extension cable, try a different one
	Bad electrical device connected to generator	Try connecting a different device
	Generator is overloaded, (overload light is on).	Perform these steps: 1: Turn off all electrical devices 2: Unplug all electrical devices 3: Shut down the engine 4: Wait several minutes and then restart the engine 5: Try connecting fewer electrical loads to the generator
	Short circuit in one of the connected devices	Try disconnecting any faulty or short circuited electrical loads

If this does not solve your problem, please contact the CLARKE Service Department.

# EXPLODED DIAGRAM - ENGINE

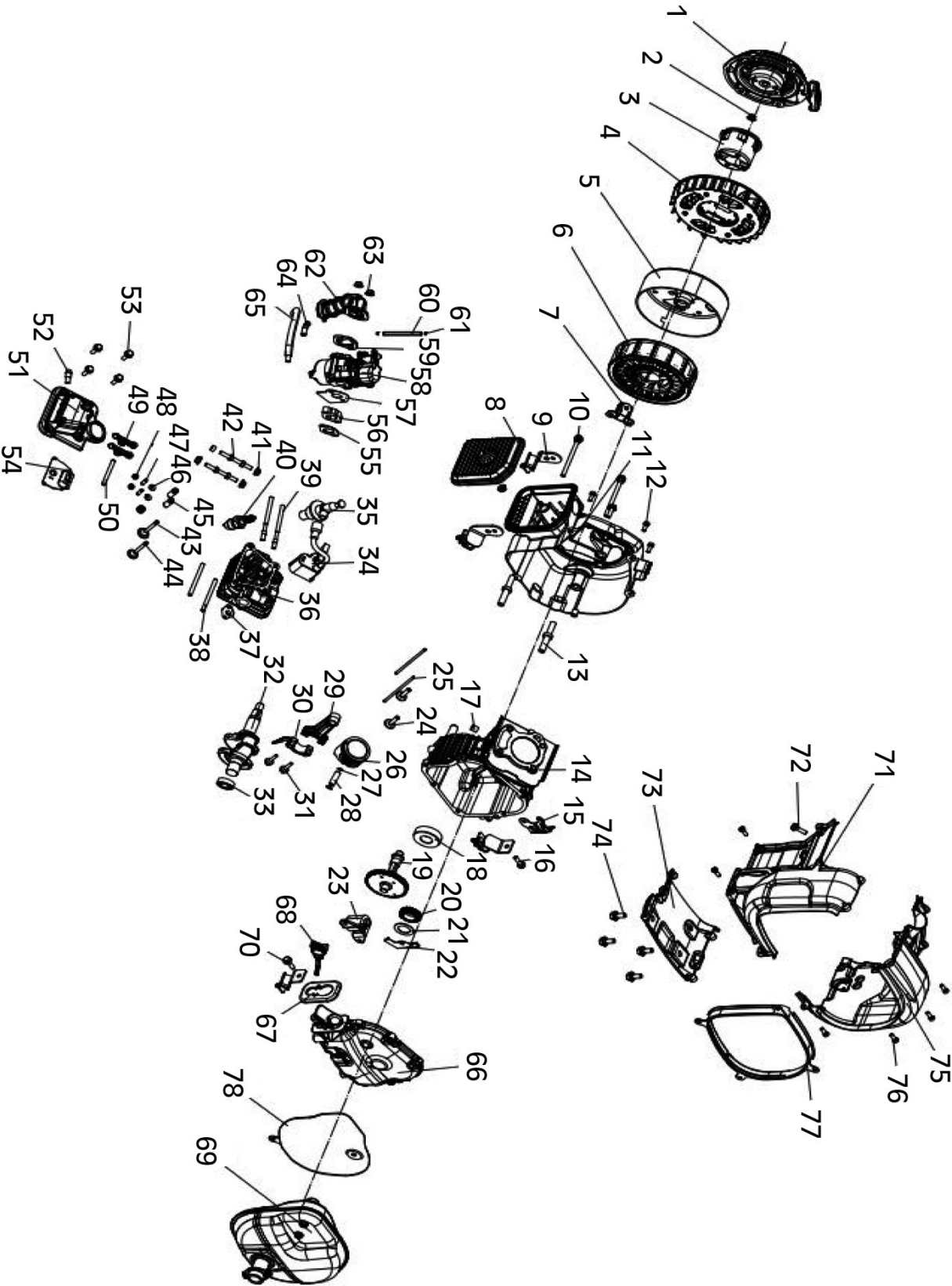



## PARTS LIST - ENGINE

<b>No</b>	<b>Description</b>	<b>No</b>	<b>Description</b>
1	Recoil Starting Assembly	24	Valve Lifter
2	Nut (M12 x 1.25mm)	25	Push Rod
3	Starting Pulley	26	Piston
4	Flywheel	27	Circlip (Piston Pin)
5	Rotor	28	Piston Pin
6	Stator	29	Connecting Rod
7	35mm Flip-Flop	30	Big End
8	Air Filter	31	Bolt
9	Damping Base	32	Crankshaft
10	Bolt (M6 x 30mm)	33	Oil Seal
11	Recoil Starter Housing	34	Spark Plug Coil
12	Screw (5.5 x 12mm)	35	Spark Plug
13	Bolt (M6 x 88)	36	Cylinder Head
14	Crank Case	37	Exhaust Valve Gasket
15	Wire Clamp	38	Bolt (M6 x 88mm)
16	Bolt (M6 x 16)	39	Bolt (M6 x 88mm)
17	Location Pin	40	Spark Plug
18	Bearing	41	Nut (M6 x 8mm)
19	Camshaft Assembly	42	Bolt (M6 x 78mm)
20	Governor Gear Set	43	Intake Valve
21	Governor Arm Shaft Gasket	44	Exhaust Valve
22	Governor Arm	45	Valve Spring
23	Oil Alert Switch	46	Valve Collet

47	Bolt	63	Nut (M6 x 8mm)
48	Nut	64	Exhaust Pipe Connector
49	Valve Rocker Arm	65	Waste Pipe
50	Valve Rocker Arm Shaft	66	Crankcase Cover Set
51	Cylinder Head Cover	67	Oil Level Gauge Cover Plate
52	Exhaust Pipe Connector	68	Oil Gauge Set
53	Bolt	69	Muffler
54	Limit Plate	70	Bolt (M6 x 12mm)
55	Intake Gasket	71	Air Duct
56	Carburetor Insulation Board	72	Bolt (M6 x 20mm)
57	Carburetor Gasket	73	Lower Duct
58	Carburetor	74	Bolt (M6 x 12mm)
59	Air Filter Gasket	75	Air Duct
60	Fuel Pipe	76	Bolt (M5.5 x 12mm)
61	Tube Clip	77	Gasket
62	Air Filter Inlet Pipe	78	Muffler Heat Shield

# EXPLODED DIAGRAM - GENERATOR

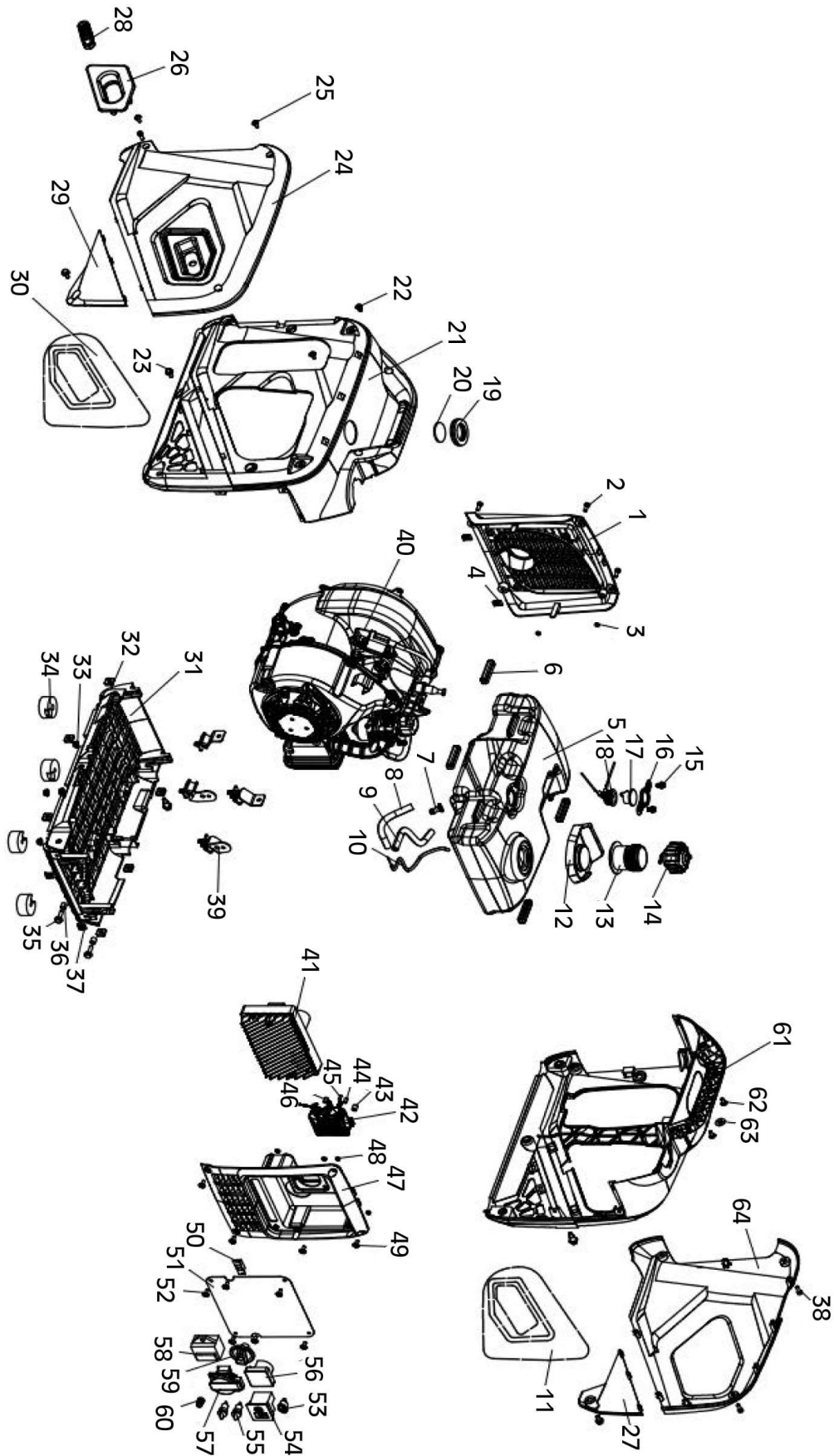

## PARTS LIST - GENERATOR

<b>No</b>	<b>Description</b>	<b>No</b>	<b>Description</b>
1	Rear Cover	24	Left Cover Plate
2	Screw (M5 x 16)	25	Screw (ST3 x10)
3	Bushing	26	Handle Trim Cover
4	Nut (M5)	27	Corner Piece Cover (Right)
5	Fuel Tank	28	Starting Handle
6	Rubber Gasket	29	Corner Piece Cover (Left)
7	Nozzle	30	Soundproofing Cotton
8	Fuel Pipe	31	Baseplate
9	Fuel Pipe	32	Nut (M6)
10	Throttle Cable	33	Nut (M6)
11	Soundproof Cotton	34	Rubber Feet
12	Gum Cover	35	Bolt
13	Fuel Tank Seal	36	Bushing
14	Fuel Tank Cap	37	Nut (M5)
15	Bolt (M6 x 12)	38	Screw (M5 x 16)
16	Pressing Plate (Oil Level)	39	Shockproof Foot
17	Fuel Meter	40	Engine Assembly
18	Fuel Meter	41	Inverter
19	Damping Ring	42	3 in 1 Switch
20	Sight-glass (Oil Level)	43	Locating Pin
21	Left Handle	44	Locating Pin
22	Screw (M5 x16)	45	Locating Pin
23	Bolt (M6 x 18)	46	Locating Pin

47	Panel Cover	56	Voltmeter
48	Locating Pin Cover	57	EU Socket
49	Screw (M5 x 16)	58	3 in 1 Indicator
50	Valve Cable Pressing Plate	59	Switching
51	Panel	60	Earth Bolt
52	Screw (M5 x 16)	61	Right Handle
53	Idling Switch	62	Screw
54	T Type Socket	63	Gasket
55	Socket (Connected to Grid)	64	Right Cover Plate

# DECLARATION OF CONFORMITY -UKCA



## DECLARATION OF CONFORMITY

This is an important document and should be retained.

We hereby declare that this product(s) complies with the following legislation: The following standards have been applied to the product(s):

- Noise Emission in the Environment by Equipment for use Outdoors Regulations 2001 IEC 62321-4:2013+AMD1:2017, EN IEC 61000-6-1:2019, EN ISO 8528-13: 2016,
- The Electromagnetic Compatibility Regulations 2016 IEC 62321-7-1:2015, IEC 62321-7-2:2017, IEC 62321-3-1:2013, EN ISO 3744:1995,
- The Supply of Machinery (Safety) Regulations 2008 EN 55012:2007+A1, ISO 8528-10:1998, IEC 62321-5:2013, IEC 62321-6:2015,
- The Non-Road Mobile Machinery (Type-Approval and Emission of Gaseous and Particulate Pollutants) Regulations 2018 IEC 62321-8:2017, ISO 17075-1:2017
- The Restriction of the Use of Certain Hazardous Substances in Electrical and Electronic Equipment Regulations 2012

The technical documentation required to demonstrate that the product(s) meet(s) the requirement(s) of the aforementioned legislation has been compiled and is available for inspection by the relevant enforcement authorities.

The UKCA mark was first applied in: 2024

<b>Manufacturer:</b>	Clarke International Ltd, Hemnall Street, Epping, Essex, CM16 4LG, United Kingdom	<b>Notified Body:</b>	TÜV Rheinland LGA Products GmbH (ID Number: 0197), Tillystraße 2, 90431 Nürnberg, Germany
<b>Product Description:</b>	Inverter Generator	<b>Assessment Procedure:</b>	Annex VI of above noise legislation
<b>Model Number(s):</b>	IG2300	<b>Measured LWA:</b>	93.5 dB
<b>Serial/Batch Number:</b>	Refer to product/packageing label	<b>Guaranteed LWA:</b>	95 dB
<b>Document Holder:</b>	Alan Pond	<b>Signed:</b>	 J.A. Clarke <b>Director</b>
<b>Date of Issue:</b>	25/06/2024		

IG2300 UKCA Clarke DOC 062524

Page 1 of 1

# DECLARATION OF CONFORMITY - CE



## DECLARATION OF CONFORMITY

This is an important document and should be retained.

We hereby declare that this product(s) complies with the following legislation: The following standards have been applied to the product(s):

2000/14/EC	Outdoor Noise Directive	IEC 62321-4:2013+AMD1:2017, EN IEC 61000-6-1:2019, EN ISO 8528-13: 2016,
2014/30/EU	Electromagnetic Compatibility Directive	IEC 62321-7-1:2015, IEC 62321-7-2:2017, IEC 62321-3-1:2013, EN ISO 3744:1995,
2006/42/EC	Machinery Directive	EN 55012:2007+A1, ISO 8528-10:1998, IEC 62321-5:2013, IEC 62321-6:2015,
2016/1628	Particulate Emission and Type-Approval for Non-Road Mobile Machinery Regulation	IEC 62321-8:2017, ISO 17075-1:2017
2011/65/EU	Restriction of Hazardous Substances (RoHS) Directive	

The technical documentation required to demonstrate that the product(s) meet(s) the requirement(s) of the aforementioned legislation has been compiled and is available for inspection by the relevant enforcement authorities.

The CE mark was first applied in: 2024

<b>Manufacturer:</b>	Clarke International Ltd, Fitzwilliam Hall, Fitzwilliam Place, Dublin 2, Republic of Ireland	<b>Notified Body:</b>	TÜV Rheinland LGA Products GmbH (ID Number: 0197), Tillystraße 2, 90431 Nürnberg, Germany
<b>Product Description:</b>	Inverter Generator	<b>Assessment Procedure:</b>	Annex VI of above noise legislation
<b>Model Number(s):</b>	IG2300	<b>Measured LWA:</b>	93.5 dB
<b>Serial/Batch Number:</b>	Refer to product/packaging label	<b>Guaranteed LWA:</b>	95 dB
<b>Document Holder:</b>	Alan Pond	<b>Signed:</b>	
<b>Date of Issue:</b>	25/06/2024		J.A. Clarke Director

IG2300 CE Clarke DOC 062524

Page 1 of 1

# A SELECTION FROM THE VAST RANGE OF

# Clarke®

## QUALITY PRODUCTS



**AIR COMPRESSORS**  
From DIY to industrial, Plus air tools, spray guns and accessories.

**GENERATORS**  
Prime duty or emergency standby for business, home and leisure.

**POWER WASHERS**  
Hot and cold, electric and engine driven - we have what you need

**WELDERS**  
Mig, Arc, Tig and Spot. From DIY to auto/industrial.

**METALWORKING**  
Drills, grinders and saws for DIY and professional use.

**WOODWORKING**  
Saws, sanders, lathes, mortisers and dust extraction.

**HYDRAULICS**  
Cranes, body repair kits, transmission jacks for all types of workshop use.

**WATER PUMPS**  
Submersible, electric and engine driven for DIY, agriculture and industry.

**POWERTOOLS**  
Angle grinders, cordless drill sets, saws and sanders.

**STARTERS/CHARGERS**  
All sizes for car and commercial use.



## PARTS & SERVICE: 0208 988 7400

**Parts Enquiries**  
[Parts@clarkeinternational.com](mailto:Parts@clarkeinternational.com)

**Servicing & Technical Enquiries**  
[Service@clarkeinternational.com](mailto:Service@clarkeinternational.com)

SALES: UK 01992 565333 or Export 00 44 (0)1992 565335

**Clarke** INTERNATIONAL Hemnall Street, Epping, Essex CM16 4LG  
[www.clarkeinternational.com](http://www.clarkeinternational.com)